



The Green Hydrogen Economy now!

The green hydrogen economy is not some future dream, but ready for utilization here and now

Karl-Heinz Tetzlaff
Moerikestr. 6
D-65779 Kelkheim
www.bio-wasserstoff.de

EUROPEAN PARLIAMRNT
Brüssels 10th of January 2007



The “Green Hydrogen Economy” is a powerful answer to the energy question

- We can start the “Green Hydrogen Economy” now.
- All required technologies are available.
 - Therefore we are able to calculate the economic figures.



Big energy concerns* press us to believe:

- There is no real alternative to oil now ...
- Hydrogen is too expensive
 - More expensive than electrical power
- Conversion to hydrogen implies very high losses
 - We ought therefore to use primary energy directly
 - Hydrogen infrastructure requires huge investments
- Installation of a hydrogen economy requires half a century or more
- ...

Why do we believe this?

* global power industry and industry dominated organisations like HFP, EHA, (JTI) ...



We worship the wrong God

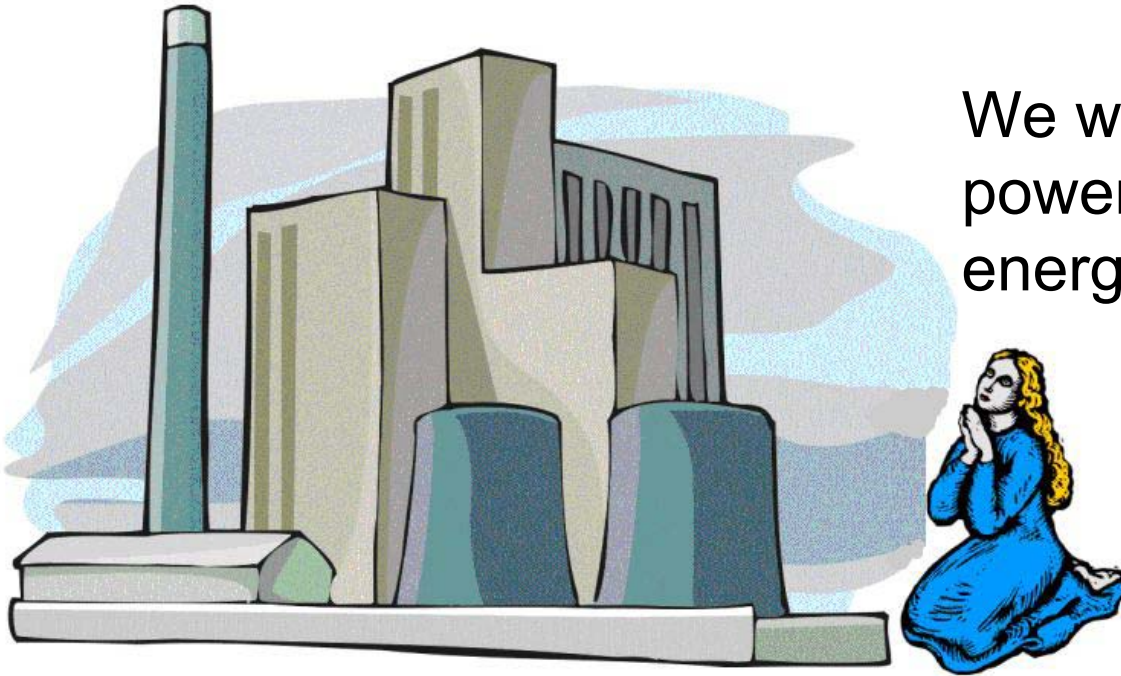

We worship the
power of
energy

The global power industry fulfills our prayers, if these lead to higher profits.

They never fulfill the “Green Hydrogen Economy”, because they will lose their business and investments in oil, gas, coal, uranium and its infrastructures in a short time



Vison or Confusion?

- We have the wrong Vision for a “Green Hydrogen Economy”
 - It is rather a confusion than a vision, because the contents of the term “Hydrogen Economy” is incorrect



The wrong Vision

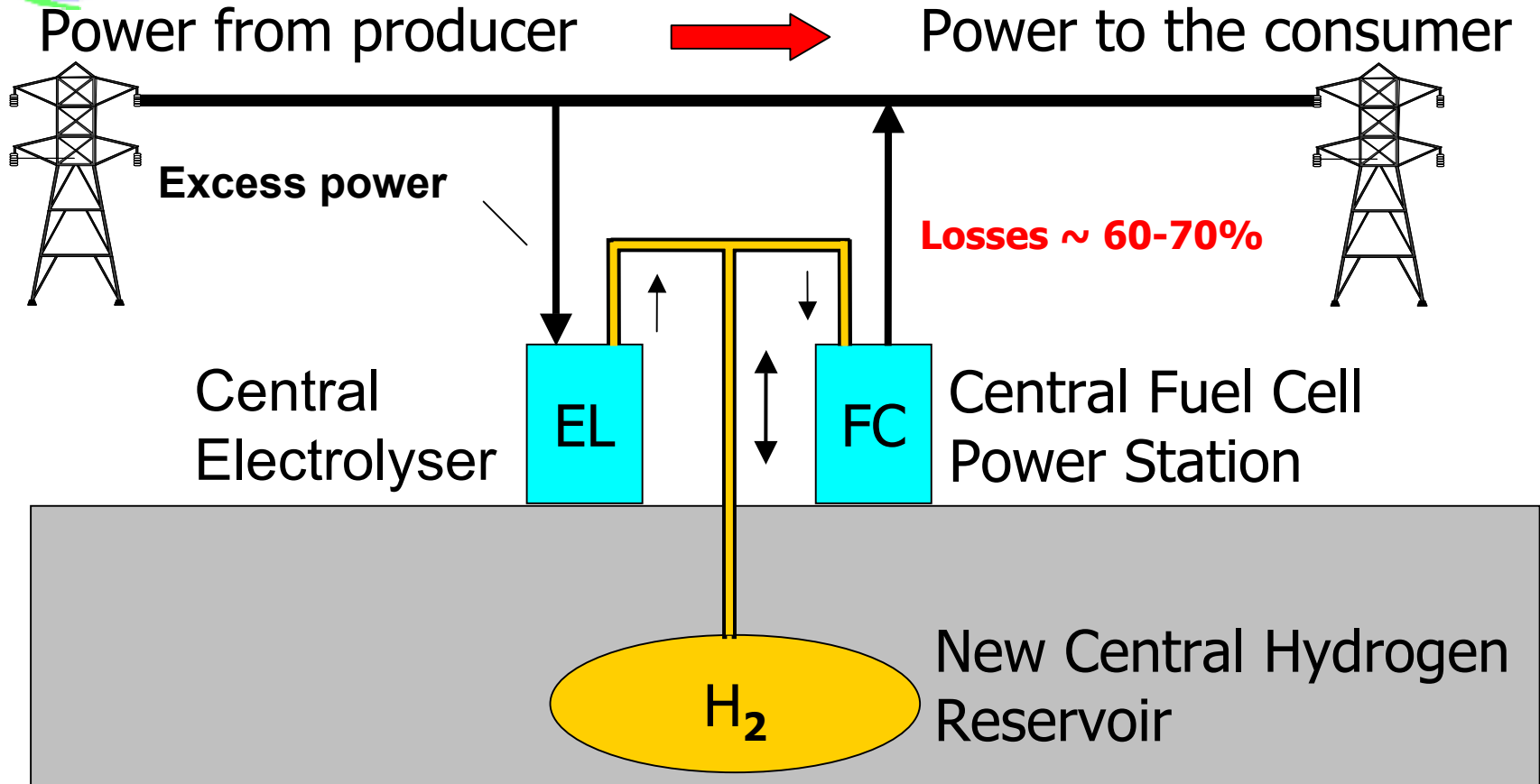

Even if some of the hydrogen is supplied to the fuel stations, it does not represent a hydrogen economy

This is only power management, because power is delivered



Green Hydrogen Economy

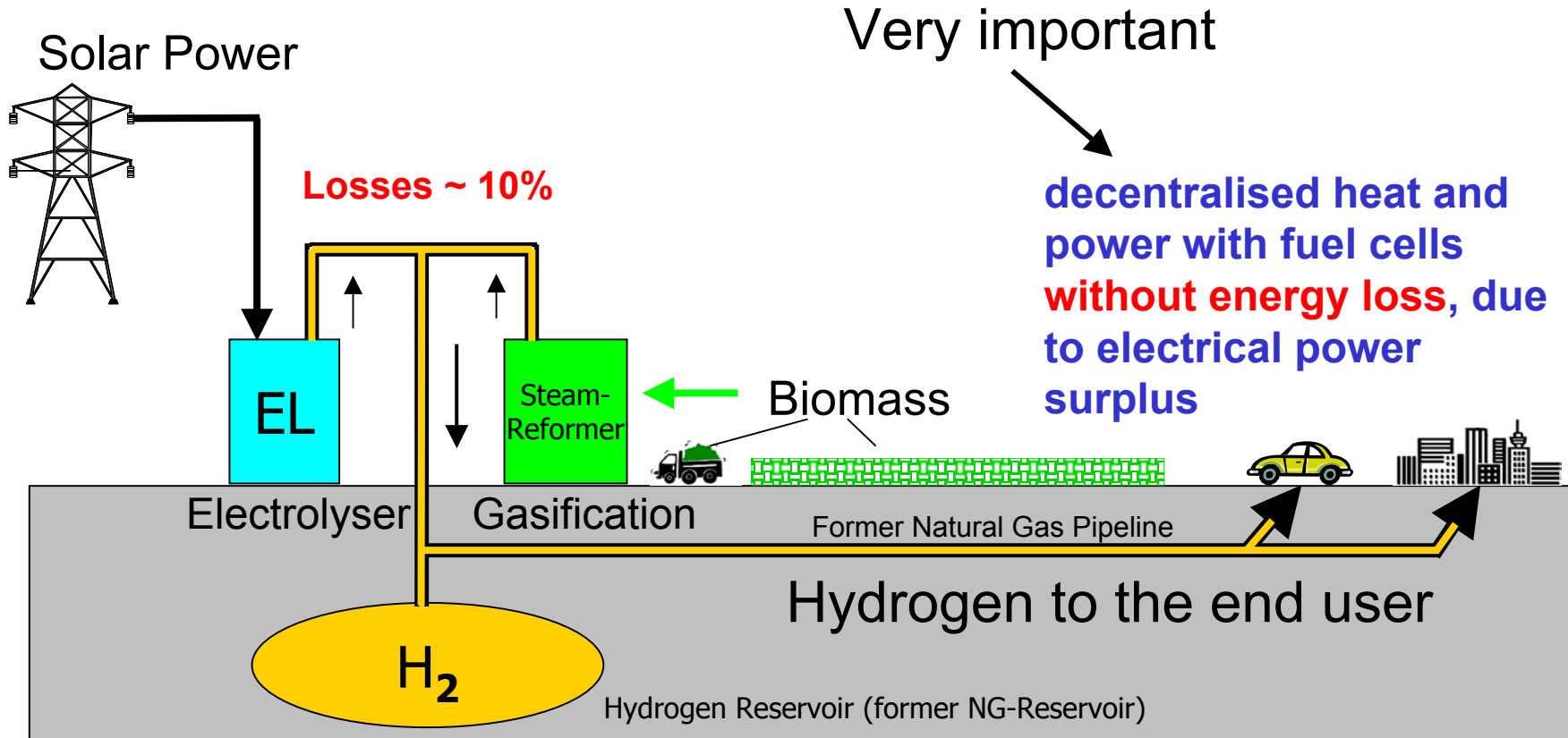

A hydrogen economy is characterized by the fact that the hydrogen is supplied to the end user. A pipeline infrastructure supplies **all energy for heat, power and vehicle fuel (!!!)**



Energy Distribution

Power supply is 10 times more expensive than hydrogen supply.

That is a further reason why hydrogen is supplied to the end user.

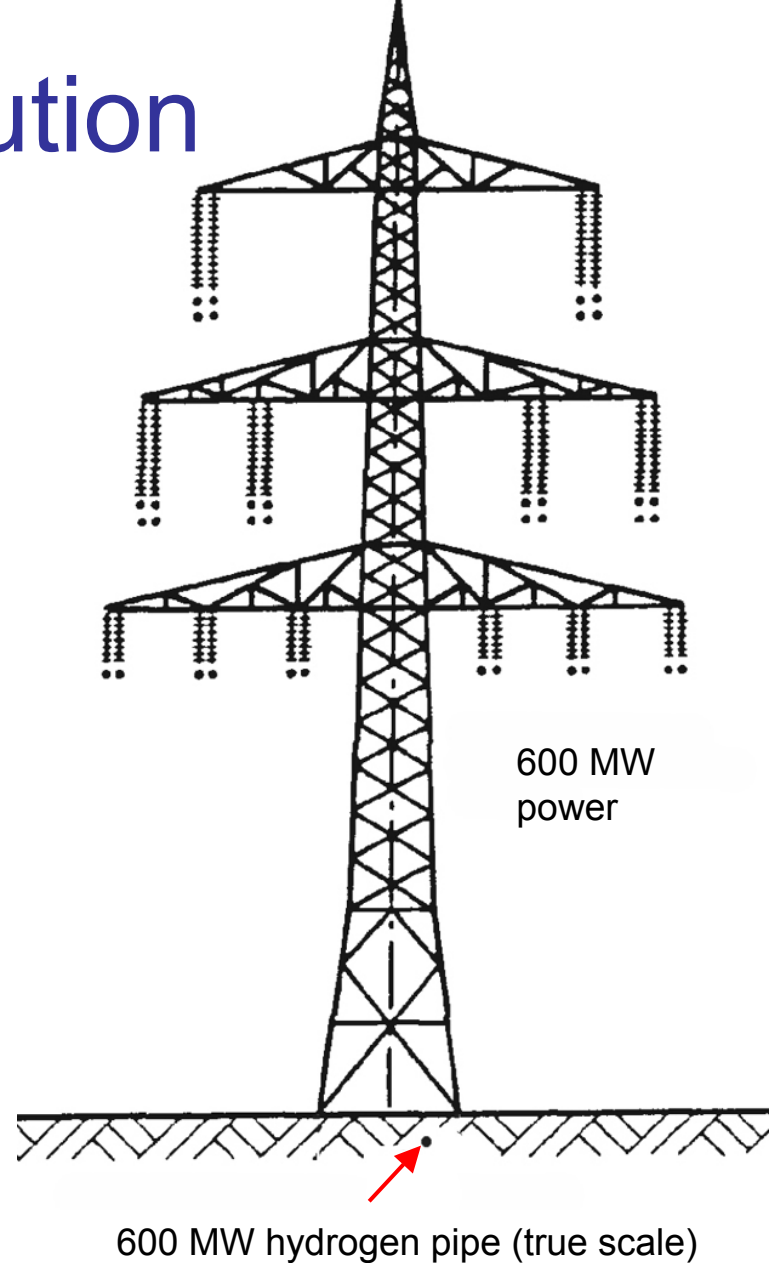



Cost of Hydrogen

Regional Steam Reformer 500 MW Hydrogen

	LHV	HHV
Payment to the farmer	0.015 €/kWh	
Loss	0.005 €/kWh	
Investment + Labour	0.005 €/kWh	
Σ= manufacturing cost	0.025 €/kWh	0.021 €/kWh
Industry rate	0.028 €/kWh	0.024 €/kWh
Household rate*	0.032 €/kWh	0.027 €/kWh*

← 73 €/tonne of dry matter (a very good price for the farmer, no subsidies needed)

← This figure is an approximation

← Your price for heat and power

All figures before tax

* Last year in Germany: NG household rate = 0.06 €/kWh (HHV, before tax)

Hydrogen from electrical power would only be competitive if less than 0.01-0.017 €/kWh (depending on fluctuation of power)



Benefits of Scale

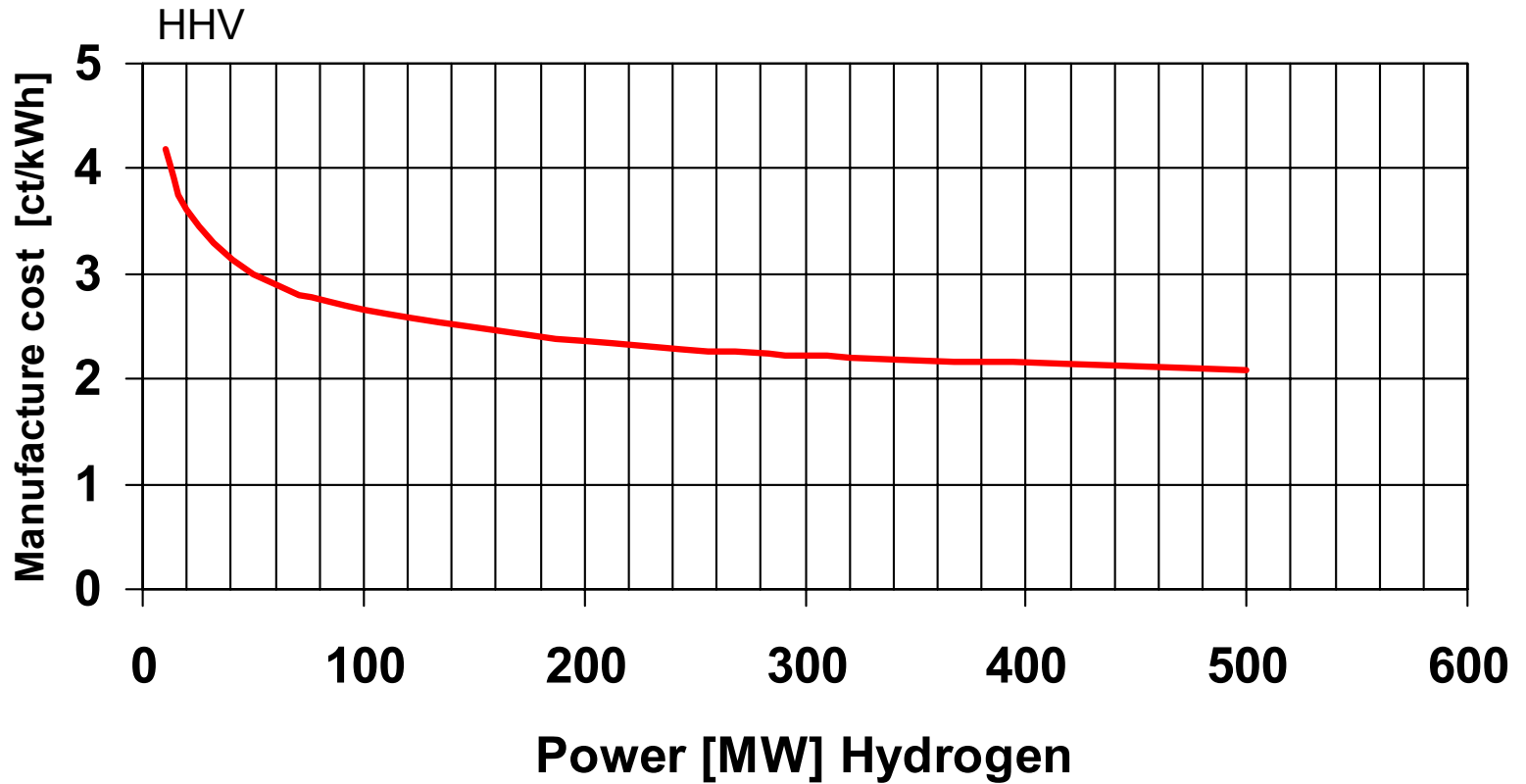



Green Hydrogen Economy in Competition (Germany)

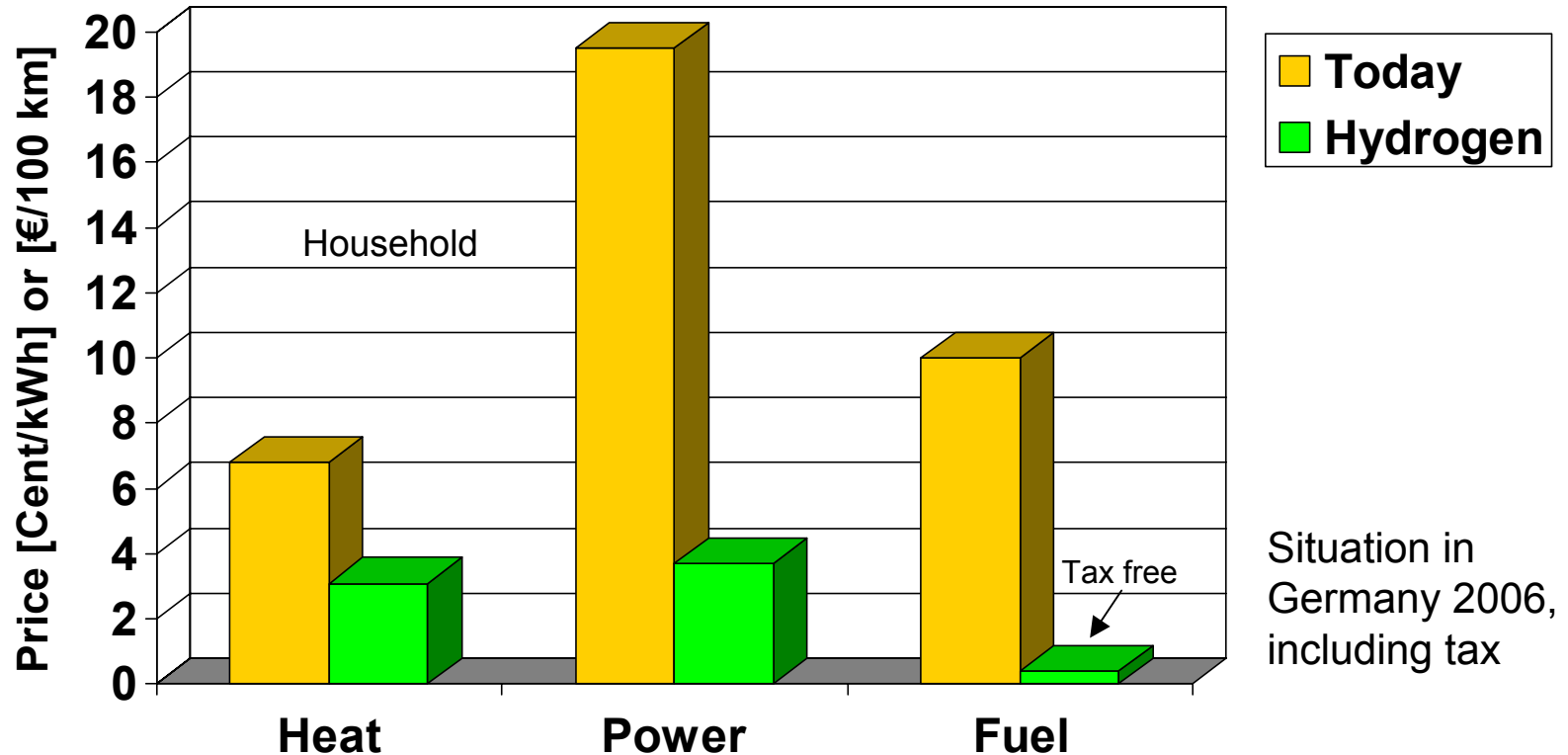

A Green Hydrogen Economy can start immediately and without fuel cells. You only have to change a little nozzle in your boiler.



Energy-Efficiency of Germany

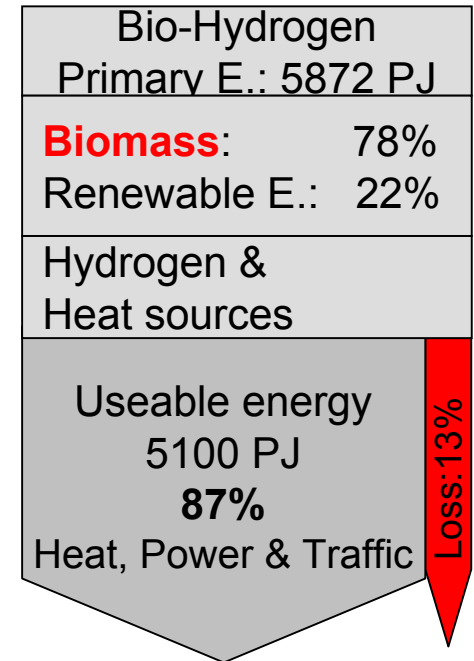
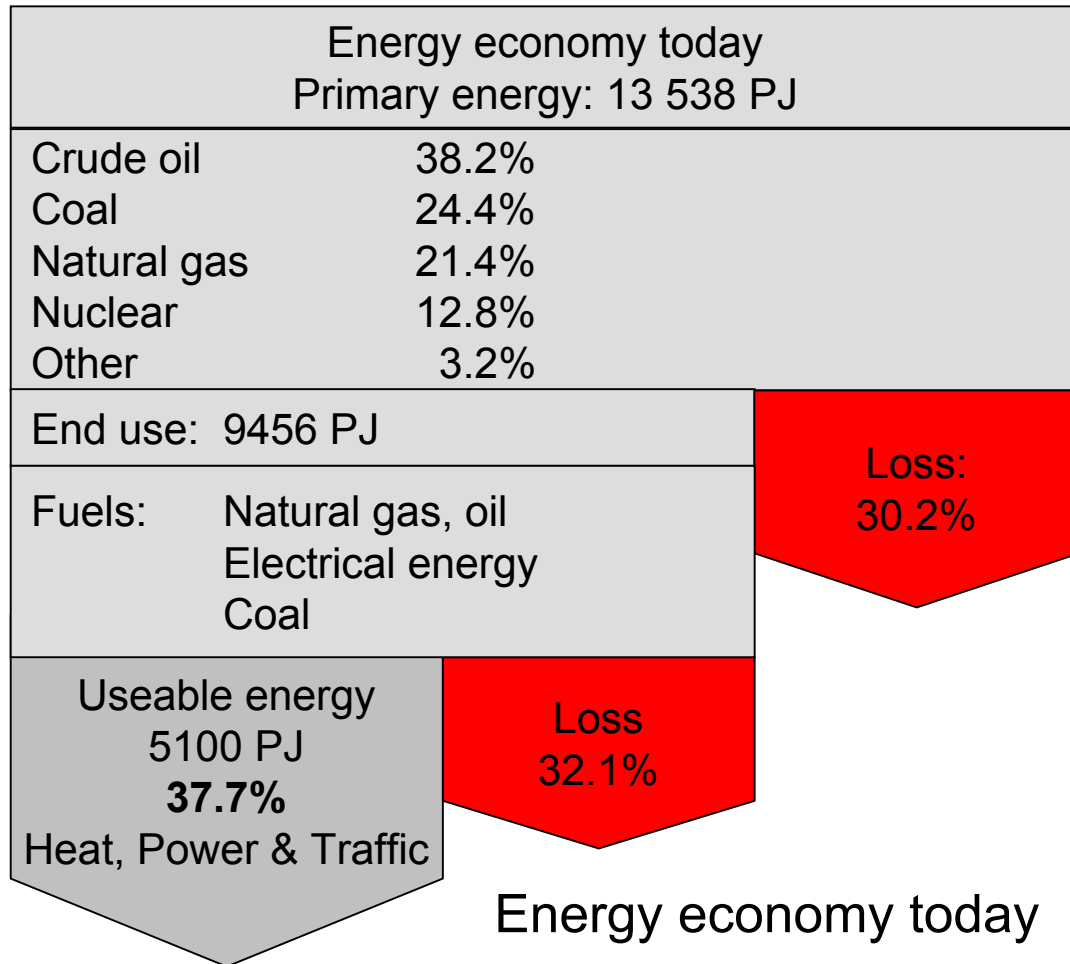



Space for Energy Plants, EU

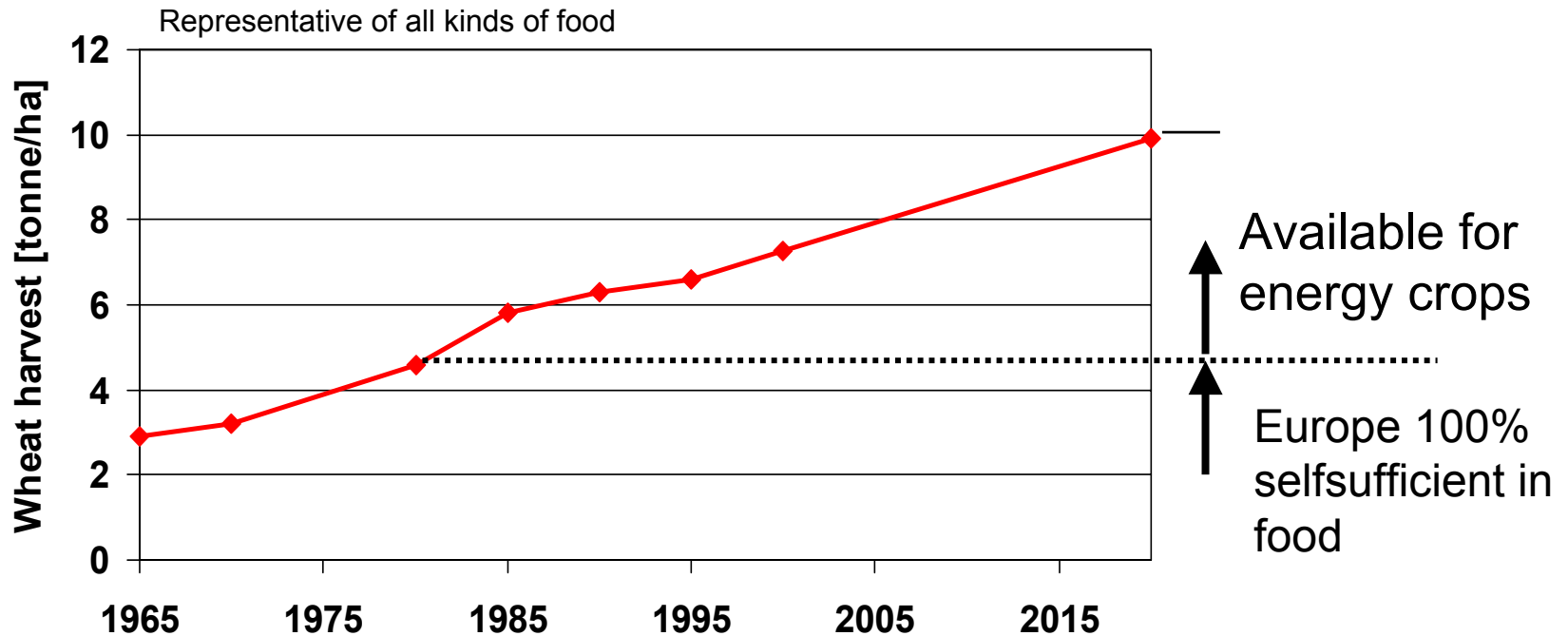

As yields increase, more and more arable land will become available to grow energy crops, which will also increase in yield



Biomass Potential Europe

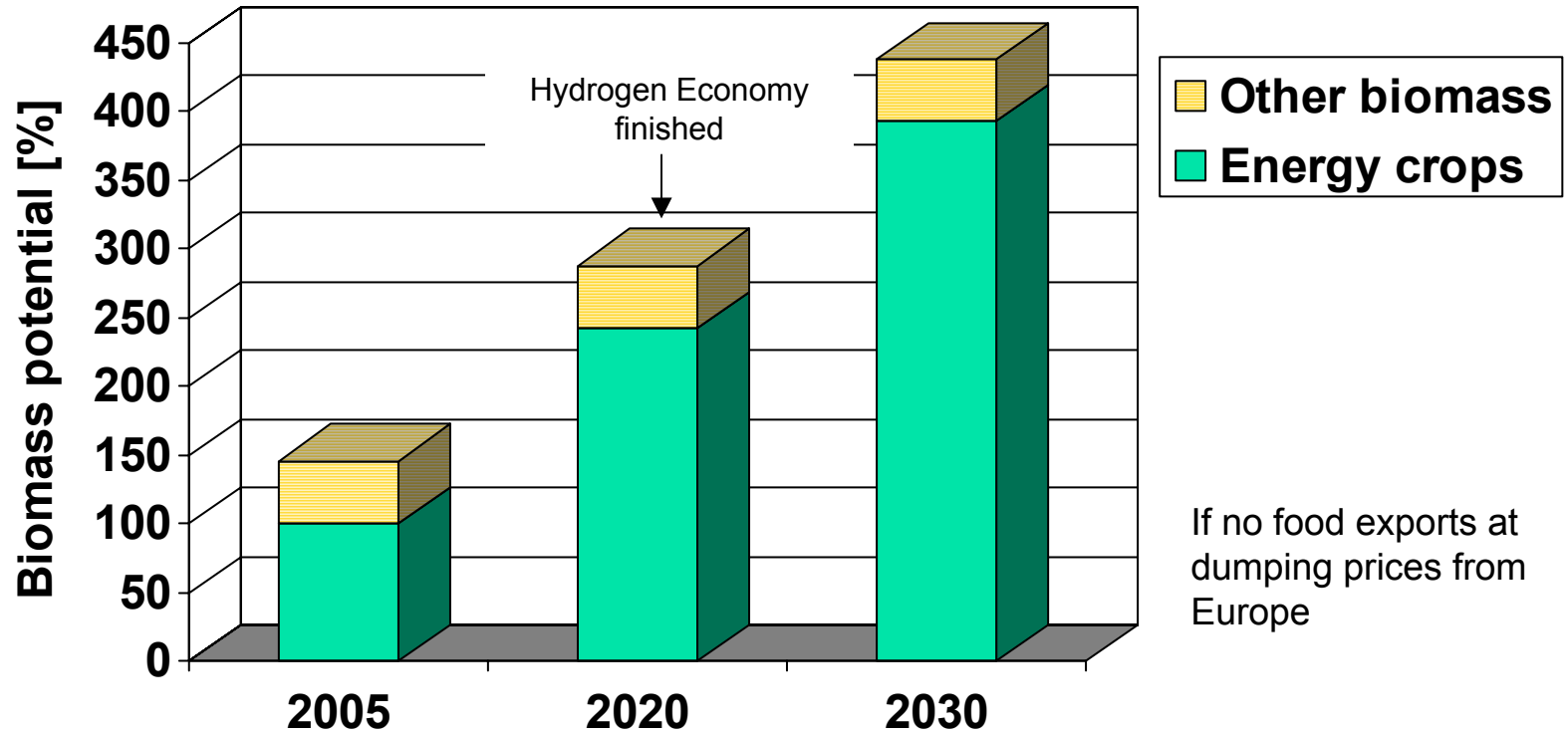

If we are optimistic, we can say: we have more than enough biomass (this Figure)

If we are pessimistic, we can say: **we have enough biomass to replace all nuclear and fossil energy**



Alternatives for Investments in Germany 2005-2020

Business as usual	10⁹ €	Green Hydrogen Economy	10⁹ €
Repair and building of power plants and national grid	200	Hydrogen factories	25
Lifting the share of renewable energies to 20% by the year 2020 (Essener Declaration)	200	Enlargement of natural gas network	10
Reconstruction of buildings to save energy	1,000	No saving of energy required	
Σ	1,400	Σ	35

Investing 35*10⁹ € for a full Green Hydrogen Economy takes only a few years, not a half century.

Please consider that fuel cell cars and fuel cell heaters will be less expensive than traditional products*.

*up to 10⁶ pieces (source:GM)



Hydrogen Technologies in Detail:



Energy crops



Source: KWS

All kinds of crops are suitable. The crops will be stored as **silage** and then gasified to hydrogen without drying



Biomass to Hydrogen Formula

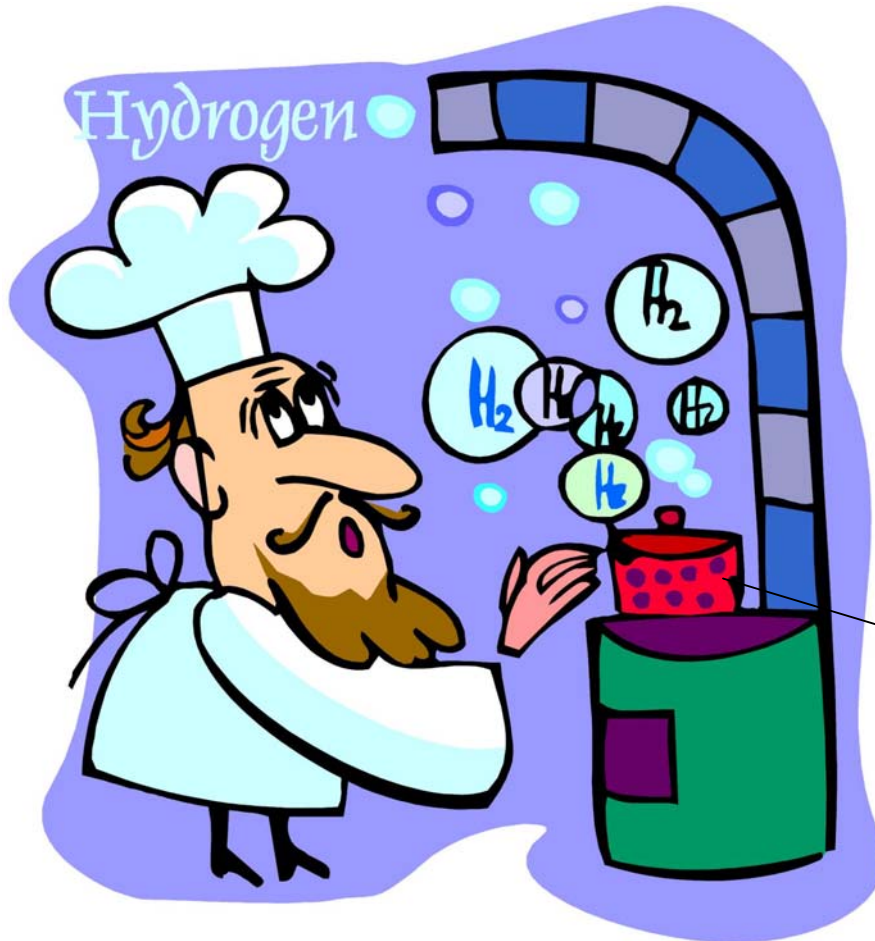

Simple recipe:



350 bar
620 °C

There is a lot R&D (Like this VERENA-project) in the pipeline. For an realistic calculation of the economic figures, we have to consider mature equipment like the old fluidised bed reactor



Hydrogen Production by industrial Fluidised Bed Reactor

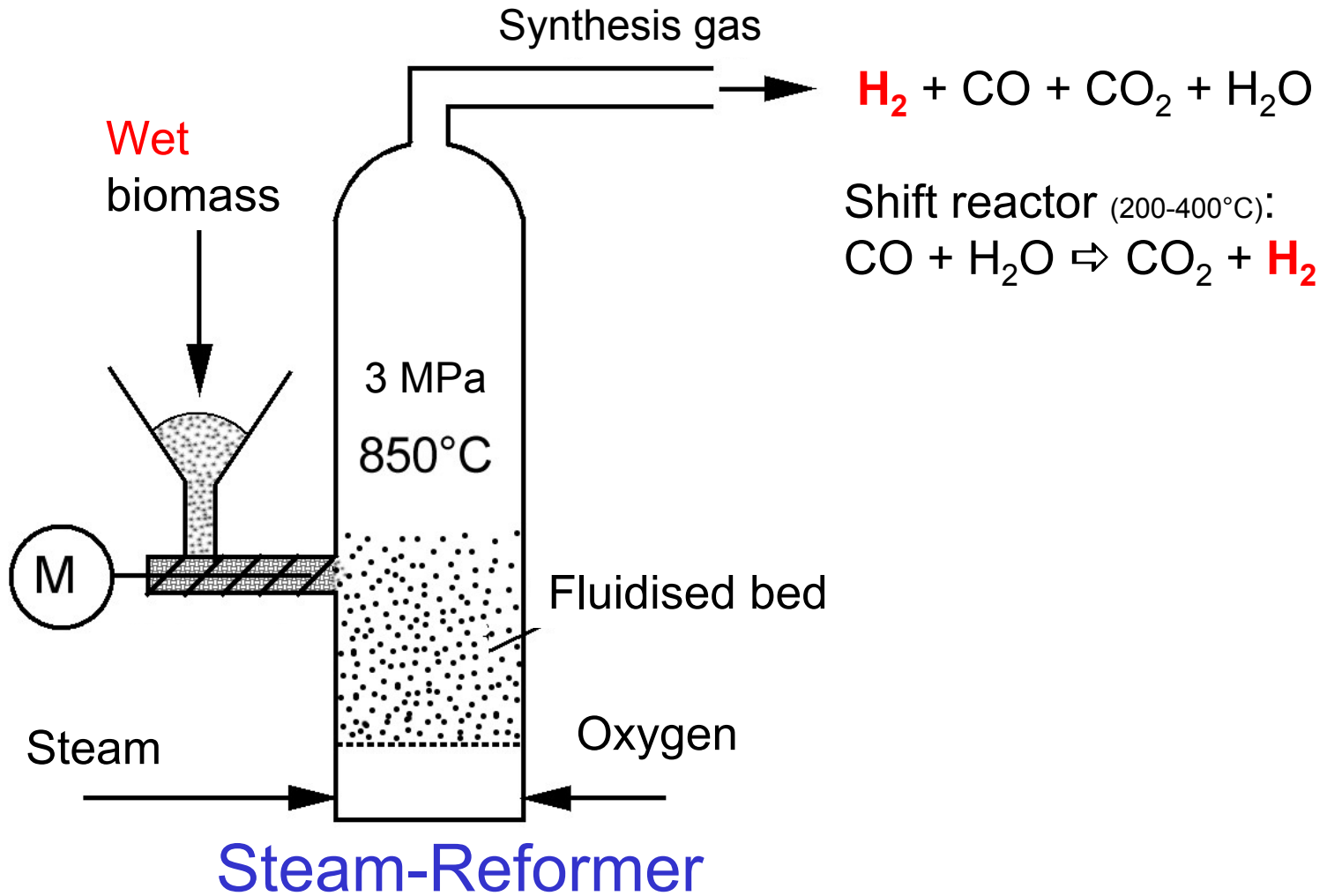



Hydrogen from Biomass

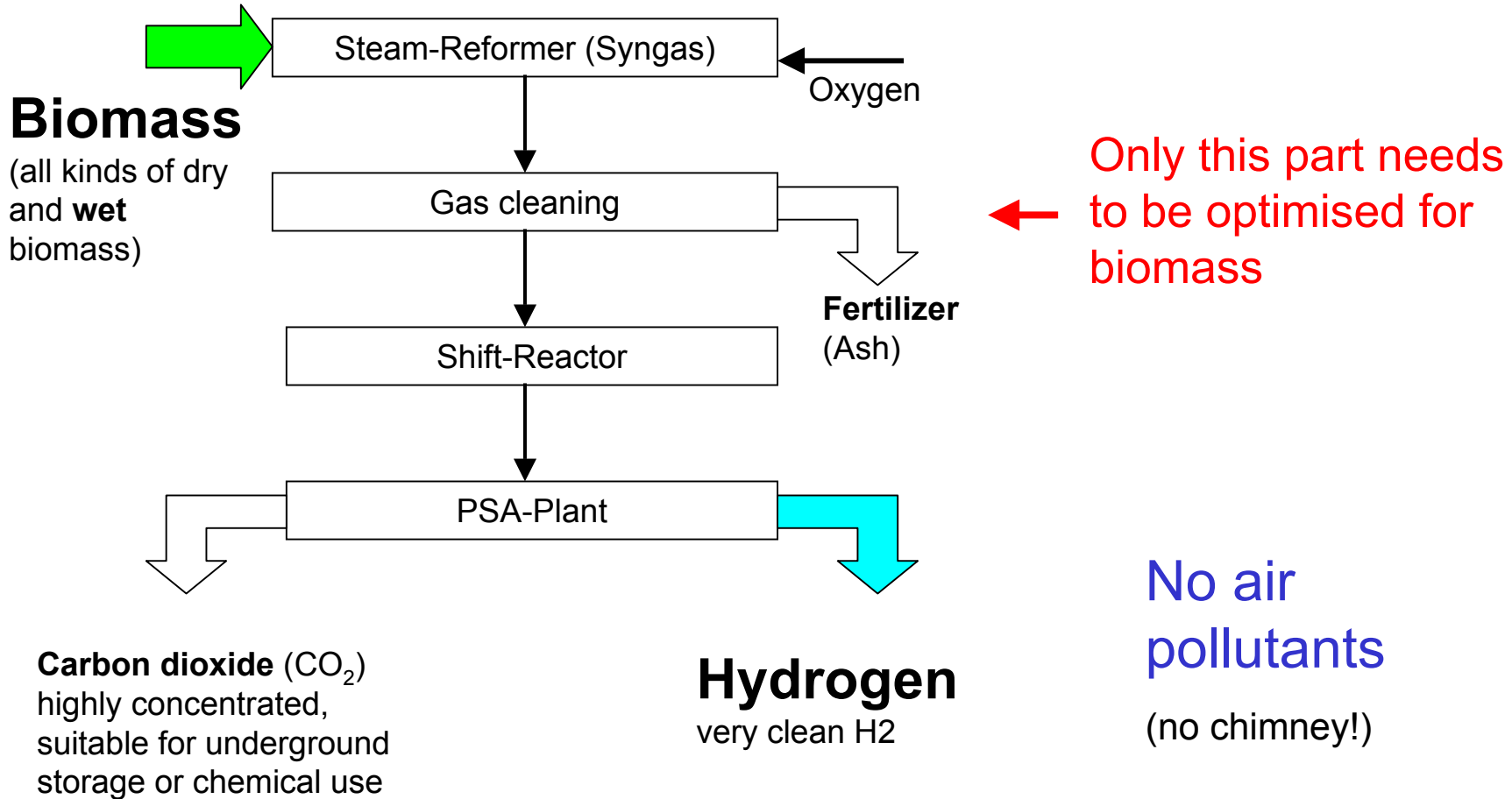

All industrialised nations have more than 150 years experience in gasification



200 MW future Hydrogen Plant



Steam-Reformer at Güssing near Vienna
(allotherme gasification)

Today pressure-less: 8 MW_(th)

The same dimensions in future:
pressured (25 bar): 200 MW_(Hydrogen)

Optimal size: 200-500 MW

Plant may be built at any
distance from the consumer,
because no waste heat is
produced.



Regionally and decentrally

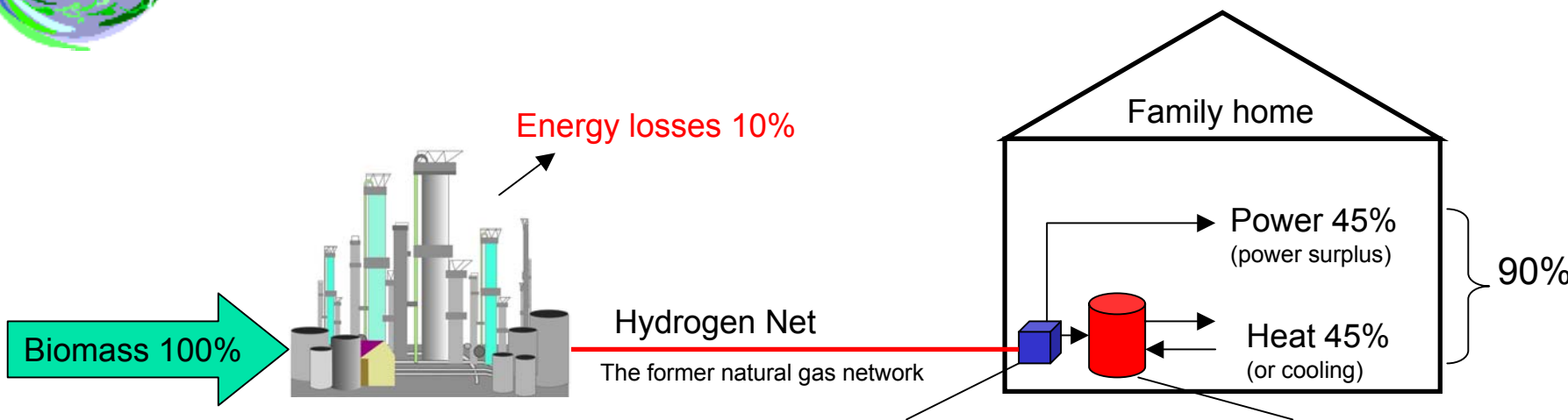

Conversion

Regionally
50-500 MW

Fuel cells deliver power immediately on request

Hot water

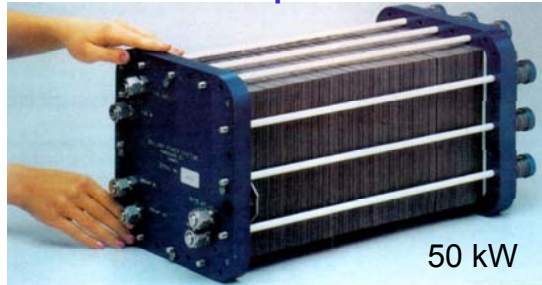

50 kW

Last year: 5,000 €/kW

Cost reduction through mass production:

2,900 pieces: **500 €/kW** (2007)*:

>10⁶ pieces: 10-50 €/kW

Start with 50 MW ¹⁾ for 16.000 family homes ²⁾

¹⁾ Farmer within a radius of 4 km supply energy crops (ø 16 t/ha, dry matter)

²⁾ 3.500 kWh Power, 15.000 kWh Heat

Today: Fuel cell power would be competitive compared to power used from the national grid

* Source: Ballard, 4-20 kW Systems



World Changing: The Green Hydrogen Economy

Today

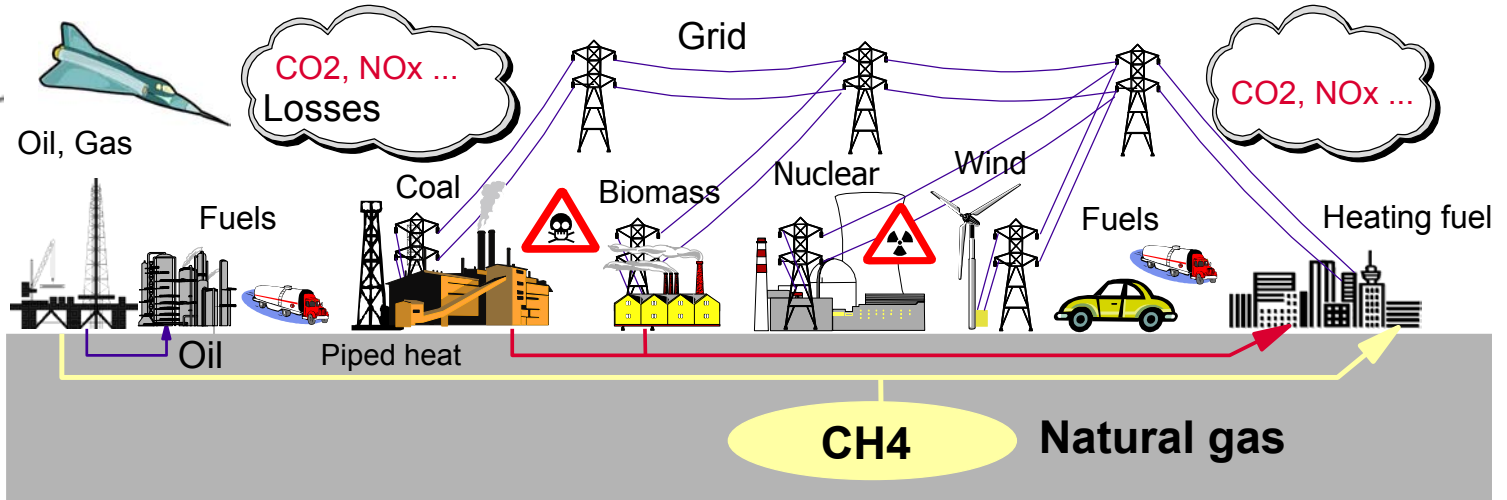

Tomorrow

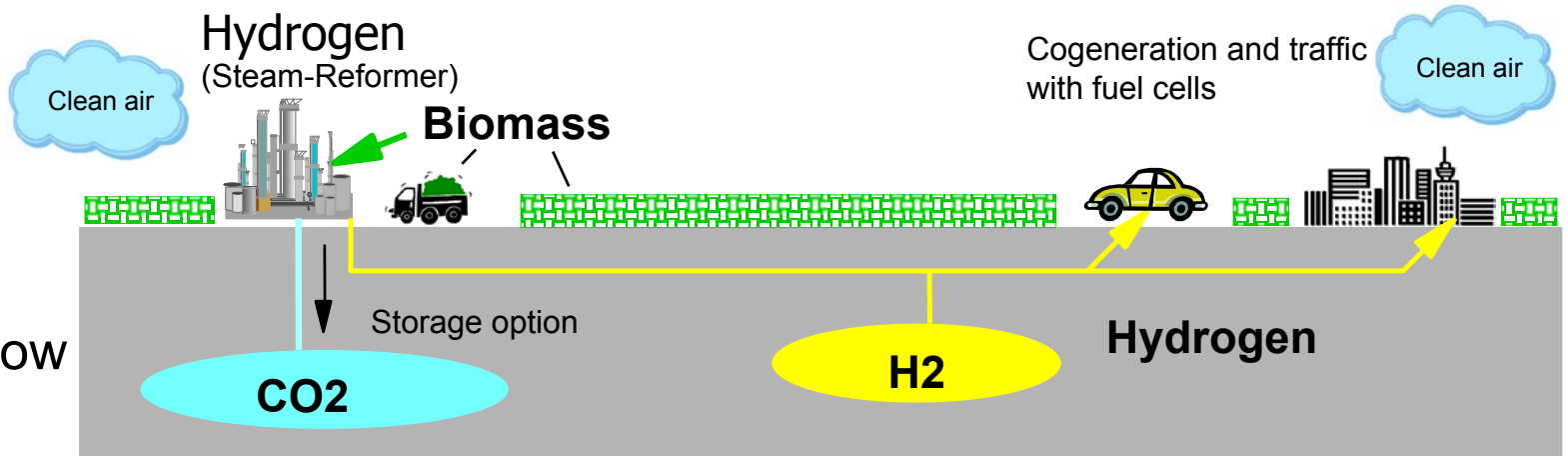



We should write a new book:

H₂-Revolution-update

Thank You for Listening



Further Information:

Bio-Wasserstoff – Eine Strategie zur Befreiung aus der selbstverschuldeten Abhängigkeit vom Öl; BoD Verlag (2005) ISBN 3-8334-2616-0

www.bio-wasserstoff.de